



Ideal Power

Technical Specifications

SymCool™ Power Module, 1200V/100A Bidirectional, Double-Sided Cooling

Part Number: IPAM01210C10

Description:

The SymCool™ is a bidirectional power module with a double-sided cooling package for superior thermal performance and efficiency. It is based on Ideal Power's innovative Si B-TRAN™ with ultra-low on-state voltage drop. It incorporates temperature sensing, Kelvin current sensing, and current sharing control, which reduces parasitic impedance and enhances protection. A cascode circuit is embedded in the package for normally-off operation.

Key Features:

- Bidirectional Switching Operation
- Ultra-Low On-State Voltage Drop
- Low Switching Losses
- Double-Sided Cooling
- Switching Frequency: 30 KHZ
- Low Parasitic Inductance and Capacitance

Applications:

- Solid-State Circuit Breaker
- Battery Disconnect Switch
- Common-Emitter Applications
- T-Type Inverter
- Matrix Converter

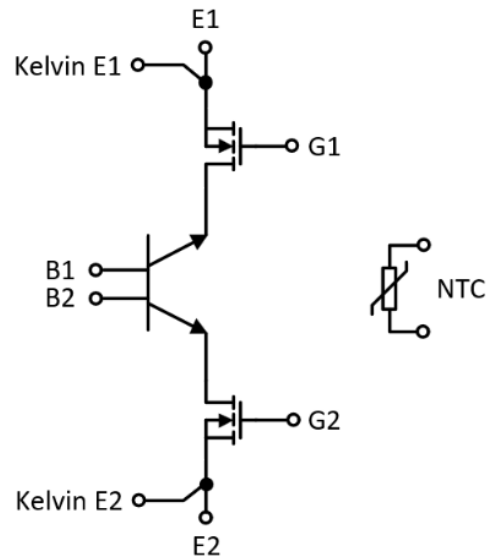

Device Circuit Symbol

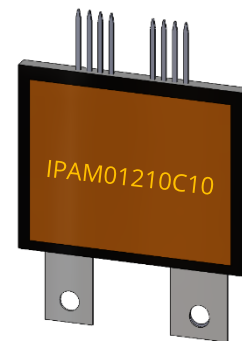

SymCool™ Package



idealpower.com

(512)264-1542

5508 Highway 290 West, Suite 120
Austin, TX 78735



1 SymCool™ Power Module DC Electrical Characteristics

Maximum Ratings

Parameter	Symbol	Value	Unit
Blocking voltage	V_{BR}	1200	V
DC emitter current $T_c = 25^\circ\text{C}$ $T_c = 100^\circ\text{C}$	I_E	100 50	A A
Pulsed emitter current	I_{Epulse}	400	A
Emitter-Base breakdown voltage	V_{EB}	50	V
Short circuit withstand time	t_{SC}	15	μs
Power dissipation $T_c = 25^\circ\text{C}$ Power dissipation $T_c = 100^\circ\text{C}$	P_{tot}	1600 400	W
Operating junction temperature	T_{vj}	-40...+125	$^\circ\text{C}$

Static Characteristics ($T_j = 25^\circ\text{C}$)

Parameter	Symbol	Conditions	Value			Unit
			Min.	Typ.	Max.	
Blocking voltage	$V_{BR(E1B2)}$ or $V_{BR(E2B1)}$	$I_{E1E2} = 100 \mu\text{A}$	1200	1300	-	V
Emitter-Emitter saturation voltage	$V_{E1E2(on)}$	V_{B1E1} or V_{B2E2} = 1.5V, $I_{E1E2} = 100\text{A}$	---	0.56	0.8	V
Base-Emitter voltage (on-state)	V_{B1E1} or V_{B2E2}	I_{B1E1} or I_{B2E2} = 1A	0.8	1	1.5	V
Emitter-Base breakdown voltage (off-state)	$V_{R(B1E1)}$ or $V_{R(B2E2)}$	I_{E1B1} or I_{E2B2} = 1mA	30	50	80	V
Emitter leakage current	I_{E1B2} or I_{E2B1}	at V_{E1B2} or V_{E2B1} = 1200V	---	200	400	μA
DC current gain	h_{FE}	$I_{E1E2} = 50\text{A}$		7	9	
	h_{FE}	$I_{E1E2} = 100\text{A}$		5	7	





Ideal Power

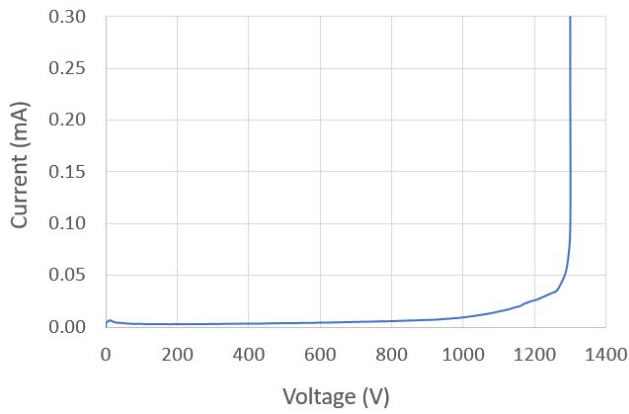

(a) Front-side

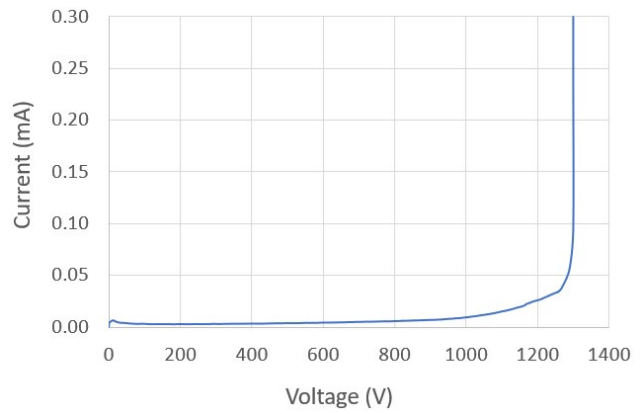

(b) Back-side

Figure 1: Breakdown voltage test curves: Front-side $V_{BR(E1B2)}$ & Back-side $V_{BR(E2B1)}$

2 SymCool™ Power Module Switching Characteristics

Switching Characteristics, Inductive Load ($T_j = 25^\circ\text{C}$)

Parameter	Symbol	Conditions	Value	Unit
Turn-on delay time	$t_{d(on)}$	$V_{E1E2} = 600 \text{ V}, I_{E1E2} = 100 \text{ A}$ $V_{B1E1} \text{ or } V_{B2E2} = 1.5 \text{ V}$	250	ns
Rise time	t_r		100	ns
Turn-off delay time	$t_{d(off)}$		450	ns
Fall time	t_f		200	ns
Turn-on energy	E_{on}		2.0	mj
Turn-off energy	E_{off}		7.2	mj
Total switching energy	E_{ts}		9.2	mj



idealpower.com

(512)264-1542

5508 Highway 290 West, Suite 120
Austin, TX 78735



Ideal Power

Switching Characteristics, Inductive Load ($T_j = 25^\circ\text{C}$)

Parameter	Symbol	Conditions	Value	Unit
Turn-on delay time	$t_{d(\text{on})}$	$V_{E1E2} = 800\text{ V}$, $I_{E1E2} = 60\text{ A}$ V_{B1E1} or $V_{B2E2} = 1.5\text{ V}$	250	ns
Rise time	t_r		140	ns
Turn-off delay time	$t_{d(\text{off})}$		450	ns
Fall time	t_f		250	ns
Turn-on energy	E_{on}		1.5	mj
Turn-off energy	E_{off}		5.8	mj
Total switching energy	E_{ts}		7.3	mj

$V_{E1E2(\text{on})}$ Test: $I_{E1E2(\text{on})}$ at 120A, $V_{E1E2(\text{on})} = 0.61\text{V}$

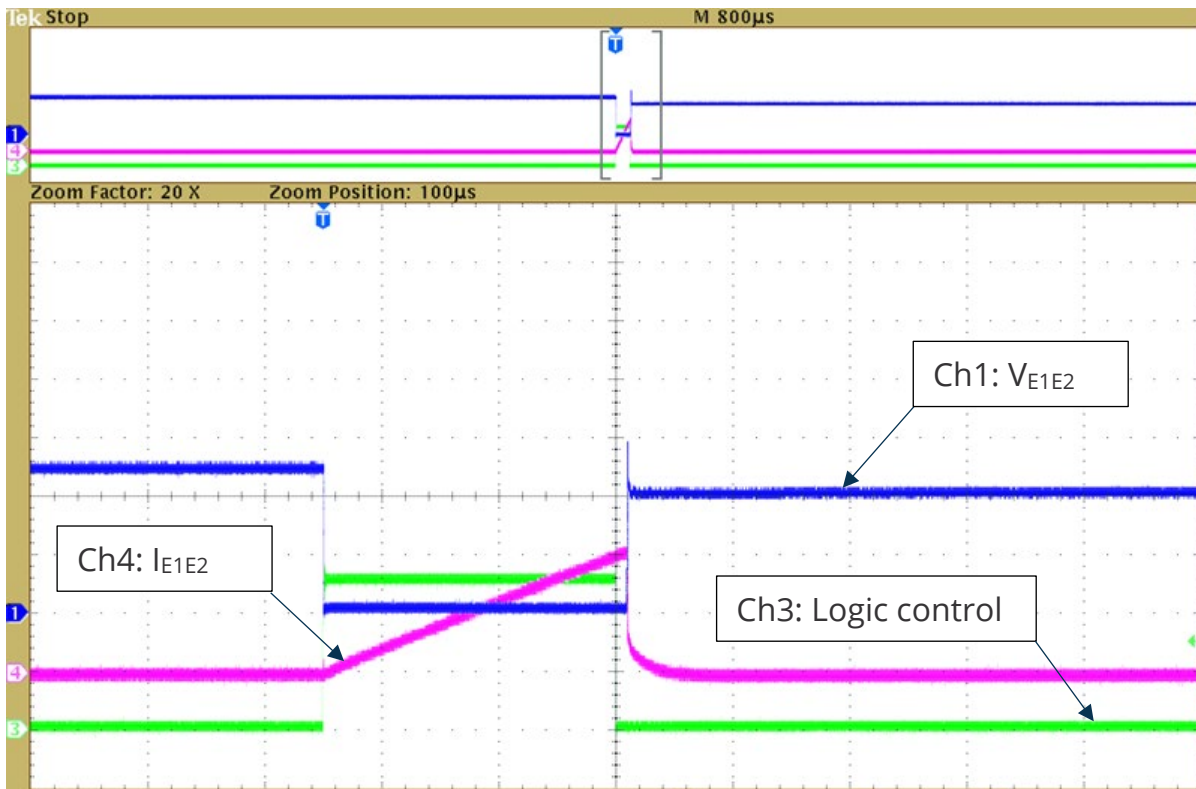

Figure 2: $V_{E1E2(\text{on})}$ test waveforms



idealpower.com

(512)264-1542

5508 Highway 290 West, Suite 120
Austin, TX 78735



Ideal Power

Double Pulse Test (DPT) Conditions: $V_{E1E2} = 800V$, $I_{E1E2} = 60A$

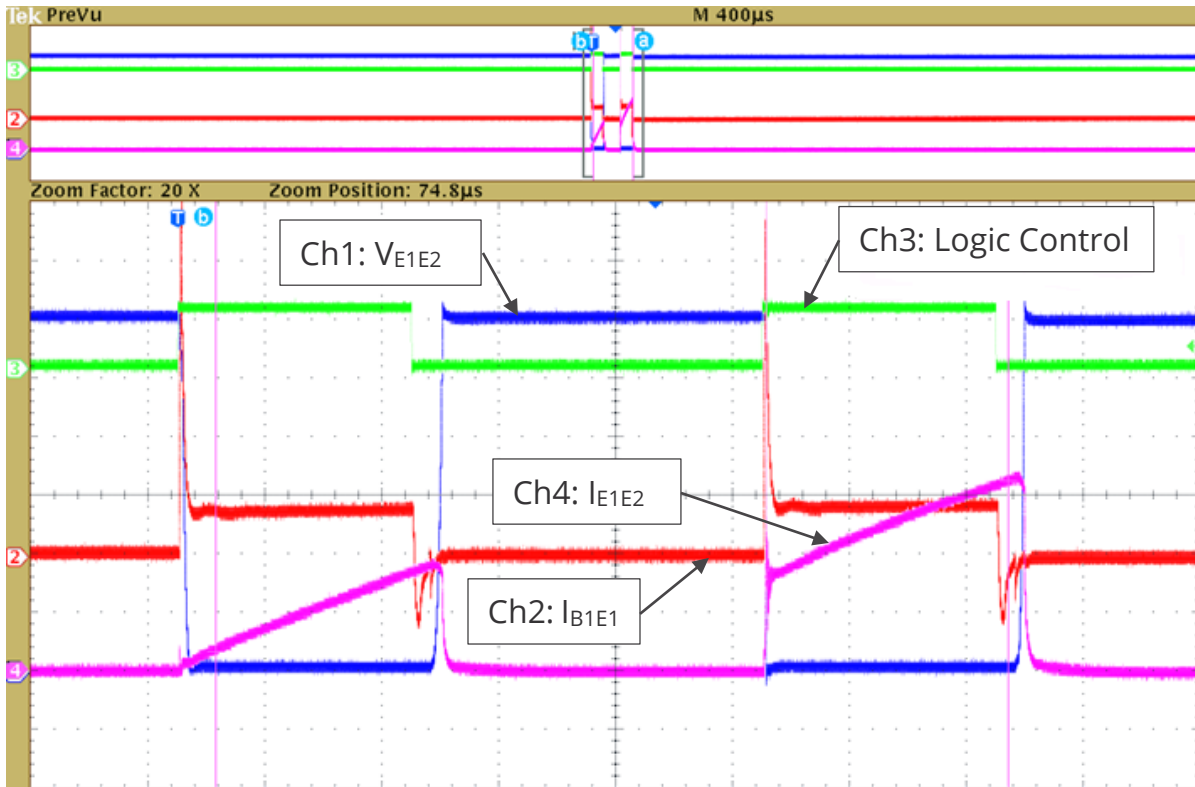

Figure 3: SymCool™ Power Module DPT waveforms



idealspower.com

(512)264-1542

5508 Highway 290 West, Suite 120
Austin, TX 78735



Ideal Power

3 NTC - Thermistor

Characteristics Values

Parameter	Value	Unit
Resistance value at 25 °C	5K	Ω
Tolerance on R25-value	± 1	%
B _{25/85} -value	3480	K
Tolerance on B _{25/85} -value	± 1	%
Maximum dissipation at 25 °C	125	mW
Thermal time constant τ	≈ 8	s
Dissipation factor D	3.0	mW/K
Operating temperature range at zero power	-40 to +150	°C
Weight	≈ 0.006	g



idealpower.com

(512)264-1542

5508 Highway 290 West, Suite 120
Austin, TX 78735

4 SymCool™ Power Module Package Information

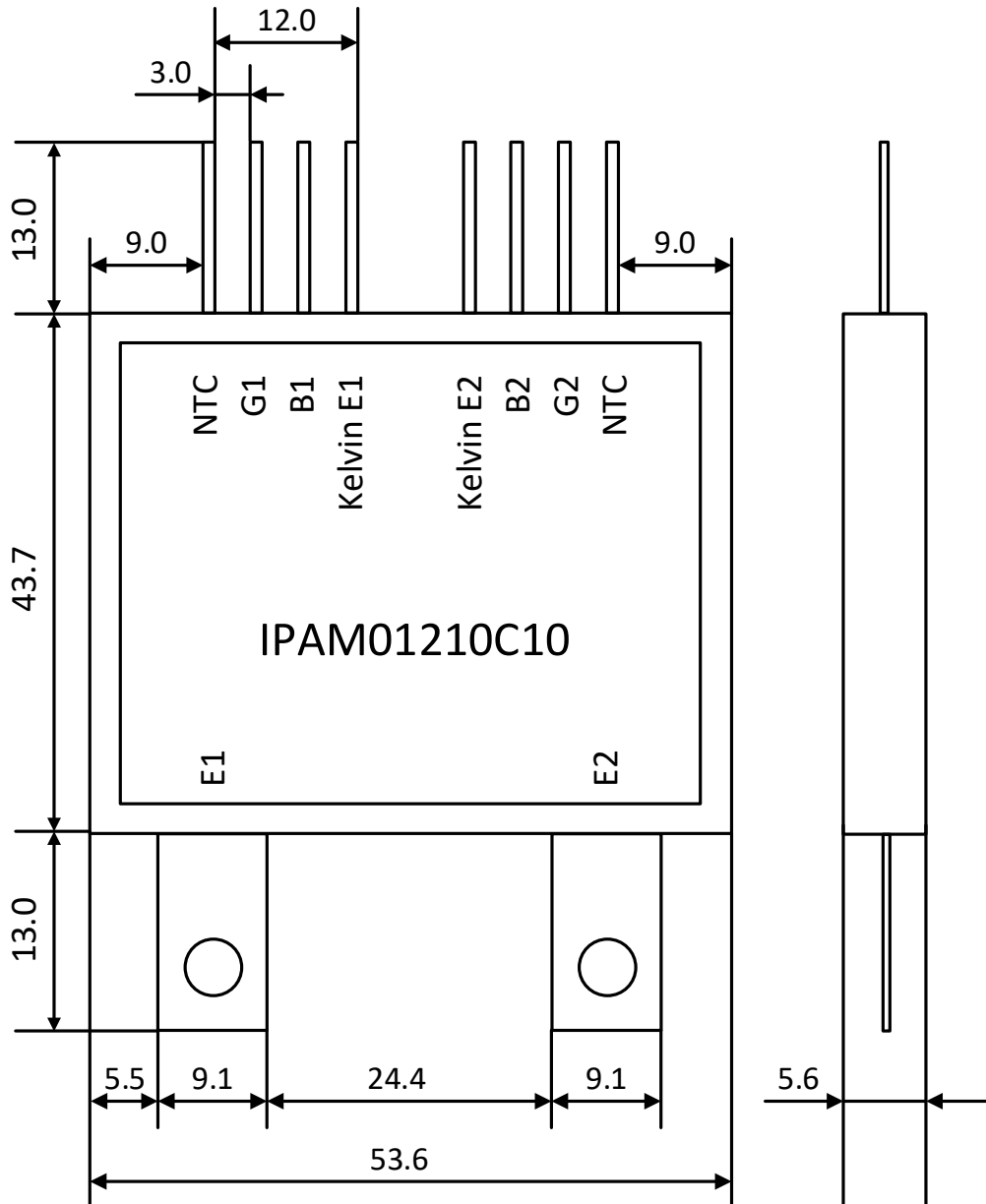

Figure 4: Mechanical outline of SymCool™ Power Module



Ideal Power

Important Notices

SymCool™ Power Module specifications are subject to change. Ideal Power reserves the right to change limits, test conditions, and dimensions without notice. Information contained in this document are typical values and shall in no event be regarded as a guarantee of characteristics. With respect to any information regarding the application of the product, Ideal Power hereby disclaims all warranties and liabilities of any kind.

The information in this document is exclusively for trained technical staff. It is the responsibility of the customer's technical department to decide the suitability of the product in the customer's application and Ideal Power assumes no responsibility or liability whatsoever for the use of the information contained in this document.

For further information, please contact sales@idealpower.com



idealpower.com

(512)264-1542

5508 Highway 290 West, Suite 120
Austin, TX 78735