

# Overview of Power Packet Switching Architecture

**IDEAL POWER's** Power Packet Switching Architecture PPSA™ is a new current-modulation technology that dramatically reduces the size, weight, and cost of Power Conversion Systems (PCS), while also increasing system efficiency and flexibility. PPSA can be applied to numerous PCS applications, including: PV Inverters, Battery Energy Storage Systems (BESS), Vehicle-to-Grid (V2G), Microgrids and AC Motor Drives. Ideal Power's patented control methodology marries high-performance semiconductor power switches with advanced software controls, dramatically reducing the weight of passive components, and eliminating the need for an isolation transformer, which is required for conventional voltage-source power conversion systems. Multiport PCS's are also part of the Ideal Power product portfolio: the direct integration of PV and energy storage is achieved by adding additional power switches and minimal additional passive components.

In 2013, Ideal Power introduced the IBC-30 Battery Converter, a bi-directional PCS targeting BESS applications. This 30kW 3-phase power converter weighs only 97 pounds, and is primarily utilized for behind-the-meter peak shaving/demand management applications. The IBC-30 offers transformerless isolation, displacing traditional converters that are 5x to 10x heavier and simplifying equipment siting and logistics, translating to installation cost

savings of \$0.05/watt or more. The IBC-30's CEC efficiency rating is 96.5%, a best-in-class number for bi-directional power converters.

In 2014, Ideal Power introduced the 30B3 product family which includes dual (AC/DC) and multiport (AC/DC/DC) product versions. These 30kW grid-resilient systems offer a new and comprehensive set of features and capabilities:

- 50Hz, 57.5Hz (Hawaii Electric - HECO), and 60Hz grid standards
- Programmable AC output voltages: 480/415/400/380 Vac + others
- Grid following mode for grid-tied applications
- Grid forming mode for microgrid/offgrid applications
- Direct integration of renewables and energy storage (multiport AC/DC/DC)
- Autonomous PV Smoothing and PV Firming (multiport AC/DC/DC)
- Advanced controls interface, common across 30kW and 125kW platforms
- Support of CEC Rule 21 Smart Inverter features
- Transformerless Isolation: 30B3 PCS weighs only 125 pounds

In 2015, Ideal Power introduced the 125B2-4F PCS. This dual port (AC/DC) 125kW converter is now certified and in production and shares a common feature set and command language with the 30B3 product family. A multiport (AC/DC/DC) 125kW version will be available in late 2016.

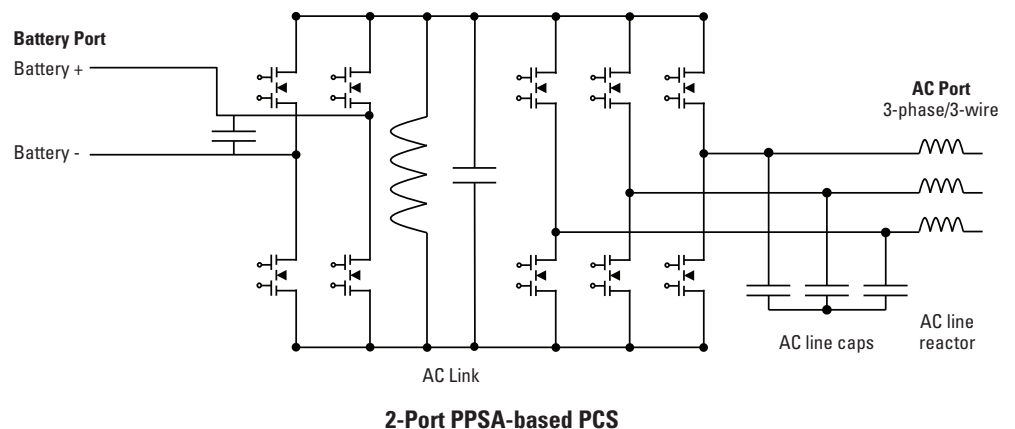

Figure 1

In the dual port Battery Converter example shown in **Figure 1**, 10 bi-directional semiconductor power switches are utilized to conduct or block bi-directional energy flows. Note that adding an additional DC port requires only 4 additional power switches and associated line capacitors, as shown in **Figure 2** below.

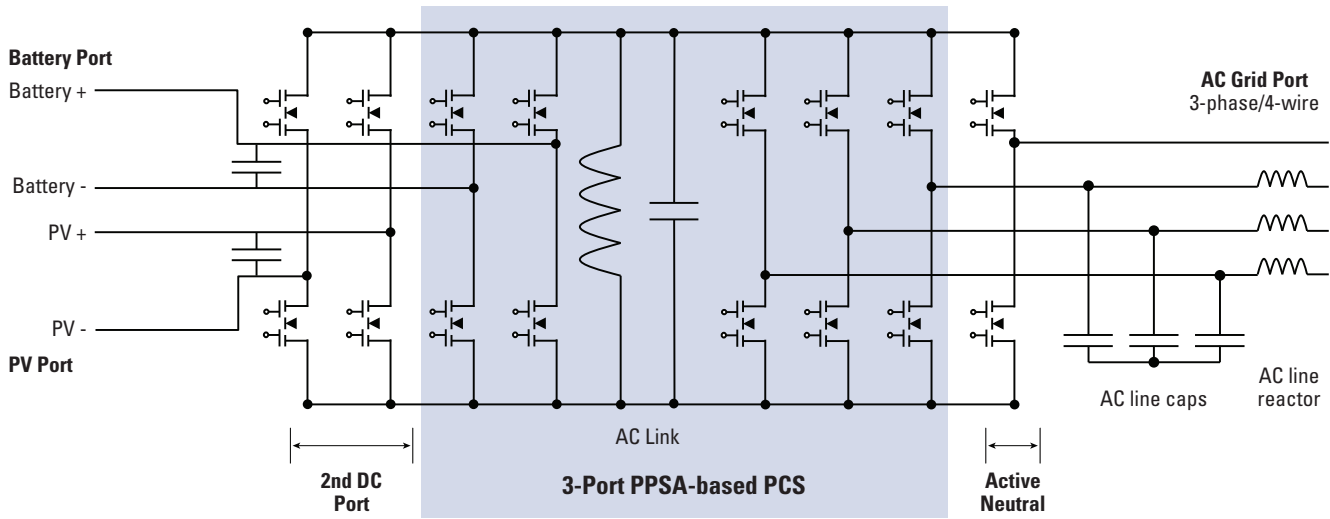

Figure 2

Today, the bidirectional power switches utilized in Ideal Power’s converters are based on Commercial off-the-shelf (COTS) silicon IGBT’s and silicon diodes. These proven components are widely used in a broad range of power systems. However, due to their electrical operating characteristics, including voltage drop, on-impedance and switching losses, these components are a major source of heat generation and subsequent system efficiency losses. Improving the efficiency and performance of semiconductor power switch components can have wide economic and performance benefits.

Ideal Power Inc. has recently received 11 US patents, and has other patents pending, for the topology and method of operation of a new kind of semiconductor power switch which we call a Bidirectional Bipolar Junction Transistor (B-TRAN). Worldwide patents are pending. Based on third party simulations, the B-TRAN is predicted to significantly improve performance over conventional power switches such as SCRs, IGBTs and MOSFETs, as implemented in silicon or wide-band-gap materials such as silicon carbide. A B-TRAN white paper is available on the Ideal Power website.

Figure 3

Standard IGBT and diodes			B-TRAN
	8	# die	2
	X	die area	0.5X
	8	# packages	2
	5V	peak $V_T$ drop	0.2V
	97%	efficiency	99%

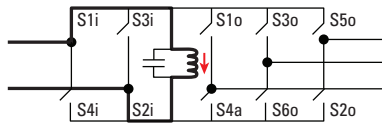

**Mode 1: Charging**

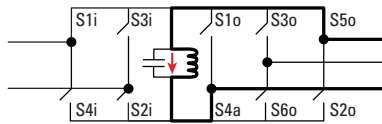

**Mode 3: Discharging**

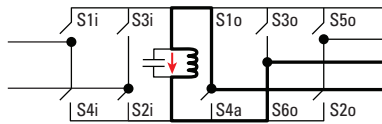

**Mode 5: Discharging**

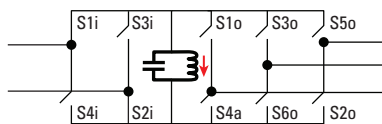

**Mode 2, 4, & 6: Partial resonance**

Figure 4

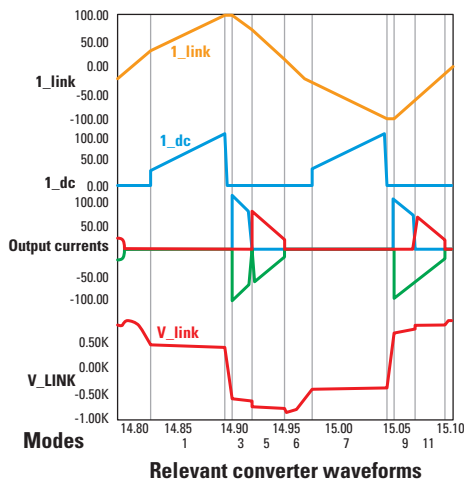

Figure 5

Ideal Power’s PPSA is based on a 100% indirect power transfer method. For example, to discharge a battery, all the energy from a DC port is forwarded (DC switches closed/ AC switches open) and temporarily stored (All switches open) in a high frequency AC Link consisting of an inductor and capacitor. This inductive energy is then forwarded (AC switches closed/DC switches open) to the 3-phase AC port. The converter’s embedded firmware and safety sense mechanisms ensure that the PCS DC and AC power ports are never directly connected to one another via “both-on” power switches. The AC Link provides circuit isolation without the size, weight and cost of an external isolation transformer. Additionally, PPSA delivers high-efficiency, near-unity power factor, and low output harmonics.

DC to AC PPSA energy transfer modes are shown in **Figure 4**. In modes two, four and six, all switches are off and the AC Link partially resonates. Then, output switches corresponding to the selected AC phase pair turn on at zero voltage as they become forward-biased by the rising Link voltage. The Link then discharges to the selected AC phase pair until specific system-generated power references are met.

**Figure 5** shows the Link voltage and current, output current and DC current. Operation in modes seven through 10 is identical to that of modes one through five except that the Link current is in the reverse direction.

The Link frequency of the IBC-30 and 30B3 product family is 7 kHz at full power. The power cycle frequency is twice this, or 14 kHz at full power, because there are two power transfers per Link cycle. All switches in PPSA converters turn on at zero voltage (no voltage differential across the switch, minimizing electrical and thermal stress). Turn-off losses are also low because there is a capacitive buffer across each switch. The converter is essentially a Pulse Width Modulation (PWM) current source, although all Link current flows are AC, with no DC offset.

In the DC to AC example shown, DC switches are turned on to charge up the Link. The Link then partially resonates, allowing it to swing to the voltage of the output phase pair to which it will subsequently discharge. The sequence of the AC phase pairs is calculated to minimize the partial resonance period while meeting the desired low harmonic levels. PPSA operation involves six operating modes. In Figure 4, note that the DC port is on the left side of the diagram and the 3-phase AC port is on the right.

**Mode 1:** depending on the polarity of the Link current, s1i and s2i or s3i and s4i turn on to charge the Link. In the example in Figure 4, switches s1i and s2i are turned on. The Link current rises as needed to extract the specified power from the battery connected to the DC port.

**Mode 2:** at the end of Mode 1, all the switches are turned off. Now, the Link resonates partially until its voltage swings and matches the first output AC phase pair. The Link then discharges (Mode 3) into the grid in two different modes in order to power the three output phases, proportionately. The instantaneous sum of the three phases is zero.

Note that the output filter results in zero phase shift between voltage and current and, at full power, the power cycle frequency of 14 kHz is much greater than the grid frequency (60Hz). Suppose that the 3 instantaneous phase voltages are  $V_{an} = 100V$ ,  $V_{bn} = -70V$ , and  $V_{cn} = -30V$ , and the Link charges to 10A during Mode 1 (voltages noted are for illustration only, they do not reflect the actual operation of the IBC-30, or 30B3). The Link would then discharge to lines AB and AC to equivalently supply 7 and 3A, respectively. This ensures that the output currents are in phase with the output voltages, resulting in unity power factor. The output discharge sequence occurs in order of decreasing instantaneous line voltages.

**Mode 3:** output switches corresponding to the selected phase pair turn on at zero voltage as they become forward-biased by the rising Link voltage. The Link then discharges to the output until specific system-generated references are met; the references are generated so as to give unity power factor at the output while maintaining low harmonic levels. In the nearby example, switches s4o and s5o turn on to let the Link discharge to phase pair AC.

**Mode 4:** as in Mode 2, switches turn off, allowing the Link to resonate until its voltage equals that of the second output phase pair. Note that as the Link resonates up (or down) to the required phase pair voltage, it is demonstrating PPSA's inherent ability to buck or boost the DC source voltage as necessary to match the phase leg voltage requirements.

**Mode 5:** switches become forward-biased to let the Link discharge to the second phase pair. In the Figure 4 example, switches s1o and s6o are enabled to discharge the Link to phase BC.

**Mode 6:** the Link is again allowed to partially resonate back to the DC input voltage to start the next discharging cycle.

**Modes 7 through 10:** are identical to modes 1 through 5, except the Link current is in the reverse direction.

### **Conclusion**

The installed base of PPSA-enabled power conversion systems has grown dramatically since the introduction of the IBC-30 Battery Converter in early 2013. Hundreds of these systems are installed in North America, and product demand continues to grow. Lastly, the enhanced capabilities of Ideal Power's second-generation 30kW and 125kW platforms further demonstrate the flexibility and scalability of this unique power switching technology. PPSA is here to stay.